

Product sheet:
HECLA®
Setores
1.000 and
1.500

With HECLA® Setores integrated steam drying and pyrolysis technology:

- You get easy “no-touch” fully automated operation
- You reduce pollution and health risks
- You eliminate greenhouse gas emissions and capture CO₂
- You recover energy and recirculate nutrients
- You reduce costs and generate revenue

Key application area:

Dewatered municipal wastewater sludge also called biosolids.

Unique technology:

The AquaGreen HECLA technology was developed and patented in collaboration with the Technical University of Denmark.

All-in-One process:

- Optimal energy balance - as low as 100 kWh/ m³ water evaporated in autothermal mode
- Super-heated steam drying for 2 hours at 120-200 °C
- Slow pyrolysis for 20 minutes at 650 °C
- Fully automated, continuous process
- Energy positive (~2 MWh/tonne dry matter)
- Autothermal emission free drying
- Oxygen-free drying with no risk of dust explosion; no ATEX zone required



Input:

- Dewatered biosolids (18-28 % dm)
- Biosolids should ideally be dewatered to 23-25% dry matter
- After anaerobic digestion, the dry matter is preferably 25-28%

Output:

- PFAS-free, low PAH biochar complying with Danish "waste to soil" PAH limit values
- Hot water (70 °C) to be used for local or district heating

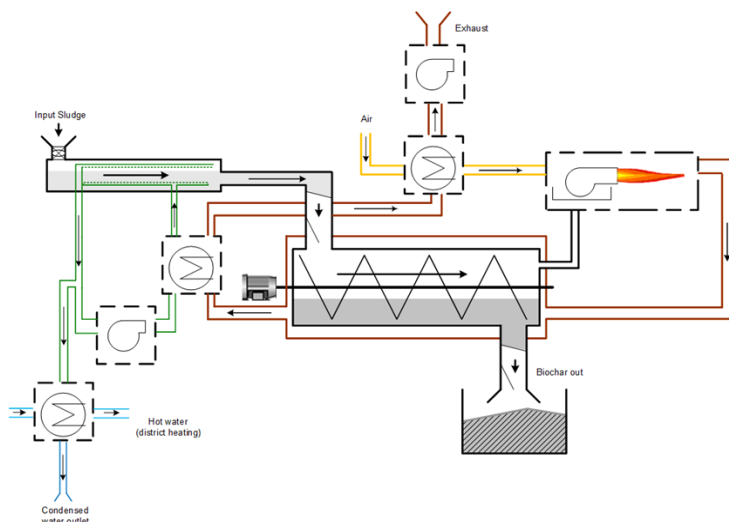

Capacity and size:

HECLA® Setores 1.000/1.500 treats 850/1300 tonnes of biosolids per year (on dry matter basis).

Unit dimensions: 15 x 14 x 5 m and 16 x 16 x 5.5 m (L x W x H) excluding feeding and receiving systems. The total weight is 45/80 tonnes.

Manpower and operation:

- Effortless operation - fully automated
- 7,000 operating hours per year
- 500 operator hours per year for monitoring and maintenance

Installation and access conditions:

The process plant must be installed in a dry, frost-free, and closed room with fresh air ventilation, waterproof flooring and floor drains. The control cabinet must either be installed in a separate room or have independent ventilation for fresh air.

Maintain a clearance of at least two meters around the entire facility. There must be access roads that allow the components of the system to be transported and mounted on the system.

Key parameters (example):

The system's capacity depends on the calorific value and dry matter content of the biomass.

HECLA® Setores	1.000	1.500	Units
Thermal drying	350	525	kW
Burner	500	750	kW
Feed rate, wet biomass	500	750	kg/h
Produced biochar	50	75	kg/h
Condensation	400	600	l/h
Cooling water	7,400	11,000	l/h

Automation and operational monitoring:

The process plant is automated with PLC control mounted in an independent control cabinet, with frequency converters on all motor components. Via an Internet connection, the system is monitored by AquaGreen with collection of all relevant sensor data and operating status parameters.

All operational data can be integrated with SCADA (Supervisory Control and Data Acquisition) systems for real-time monitoring.

AquaGreen

AquaGreen ApS
Risø Huse 50, 4000 Roskilde, Denmark
+45 53 660 888
contact@aquagreen.dk
aquagreen.dk